

Replacing the PRO3-VAQ E/ PRO7-VAQ E tank internals

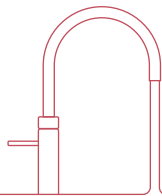

Replacing the PRO3-VAQ / PRO7-VAQ tank internals

1. Switch off the tank with the Q-shaped button on top. Do not unplug it or switch off the power yet.
2. Dispense boiling and cold water together. Leave it to run until the water is completely cold and the hose between the tap and the tank has cooled down.
3. Close the stop valve (small grey knob) on the inlet combination.
4. Open the boiling-water tap. If it is depressurised, no water will flow out of it.
5. Unplug the tank and disconnect the LED cable from the back of the tank.
6. Disconnect the flexible hose between the tap and the tank by turning the nut anti-clockwise (use spanners 10 and 14).
7. Disconnect the silver braided hose from the inlet combination by turning the nut anti-clockwise (using spanner 24).
- Remove the tank from the kitchen cabinet.

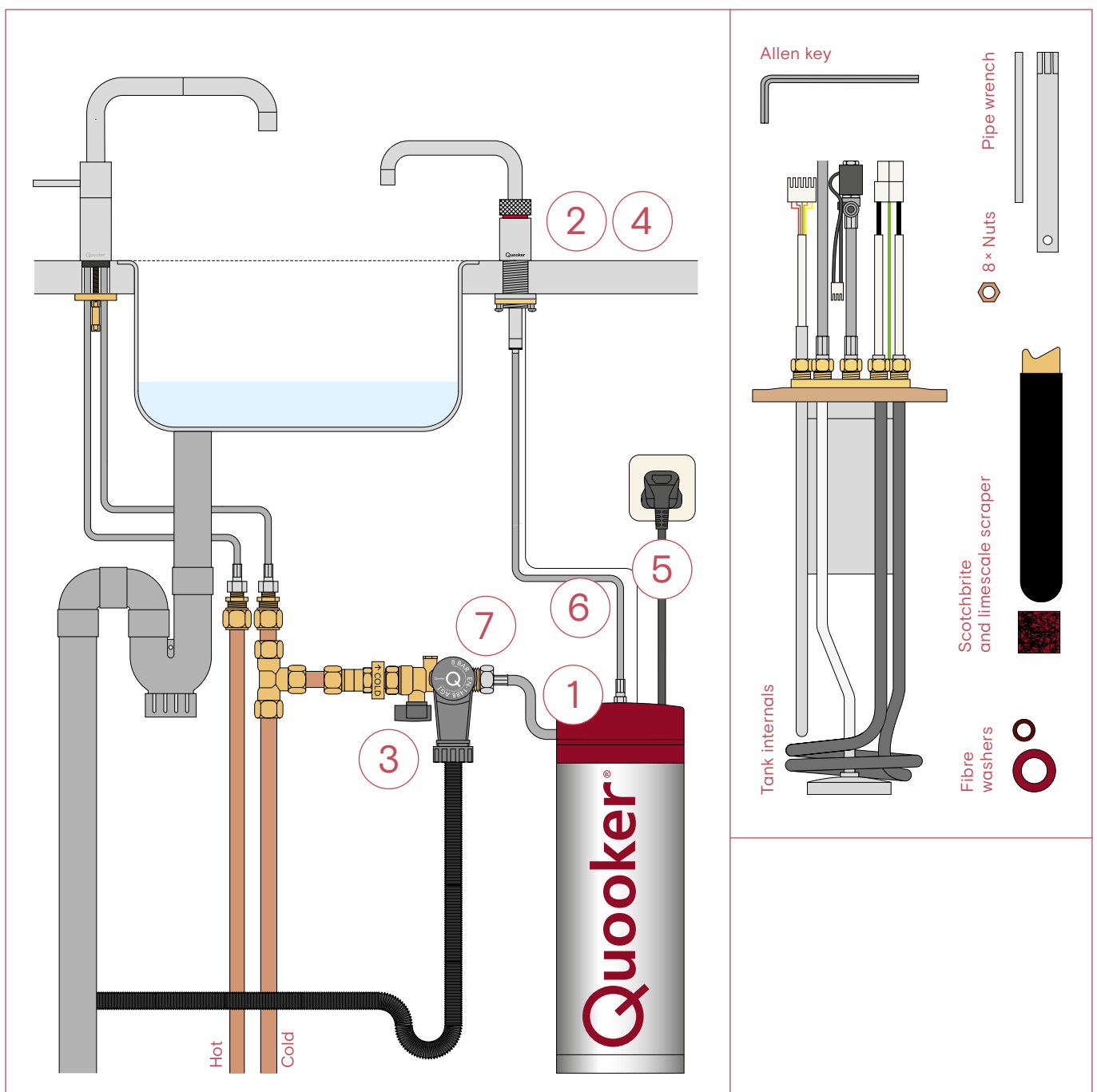

8. Unscrew the cap screws with the supplied allen key and lift the cover. Push the hose connector through the hole in the cover and gently disconnect the three wire plugs.
9. Remove the insulation.
10. Use the pipe wrench to unscrew the eight nuts anti-clockwise and remove the internals.
Please note: There is still water left in the tank.
11. Ensure that the rim of the tank is clean by using the scraper and Scotchbrite.

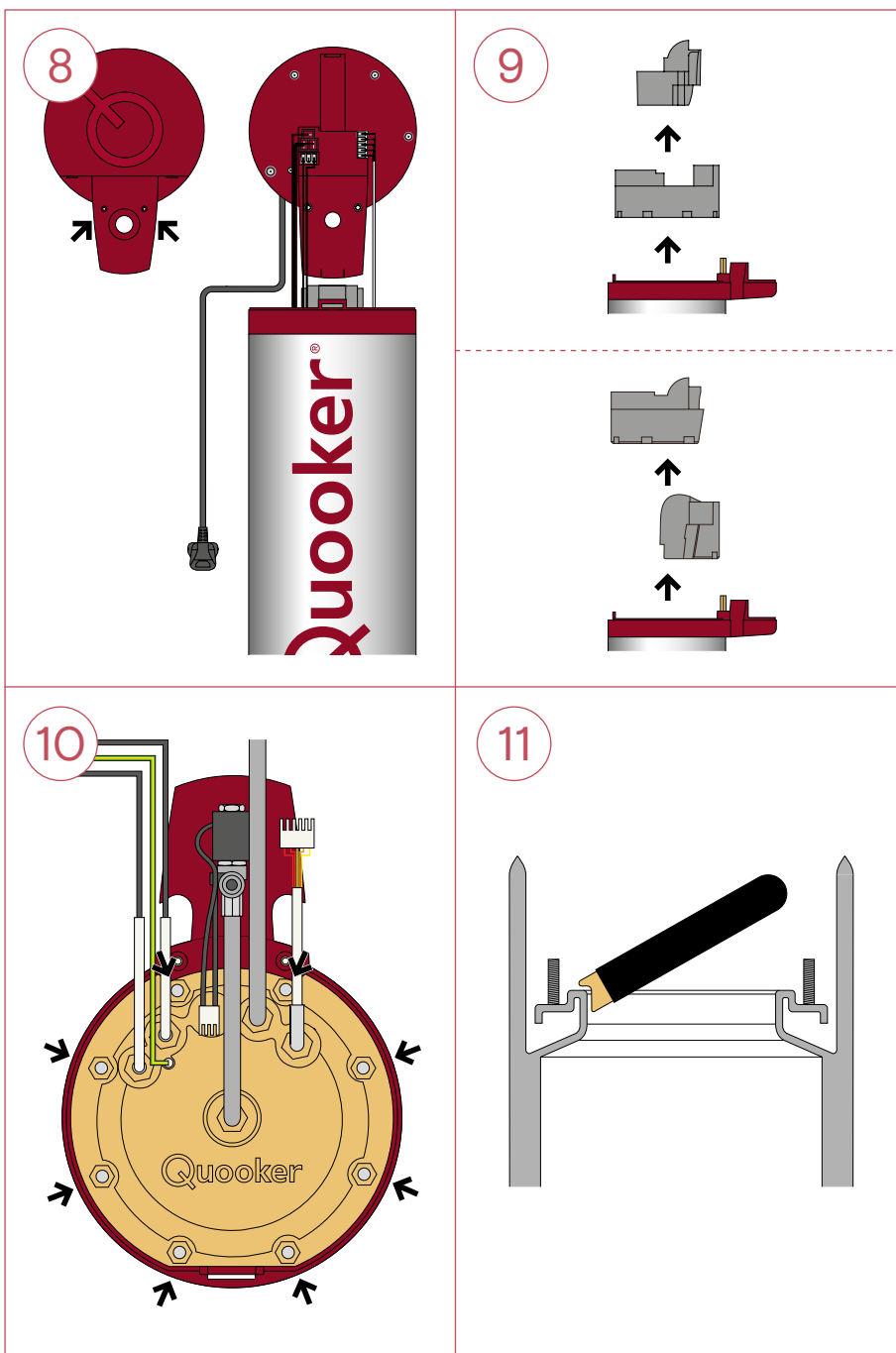

12. Dry the entire rim including the seams and bolts with paper towel, while holding the tank upside down at an angle.
13. To put the tank back together correctly, first place the tank in front of you with the red Quooker logo facing you. Accurately line up the notch of the red plastic rim with the logo on the outside of the tank.
14. Replace the internals and line up the Quooker logo on the internals with the notch of the red ring.

 - Place the eight nuts and tighten them in a diagonal sequence.

15. Now turn the tank a quarter turn clockwise. Replace the insulation.

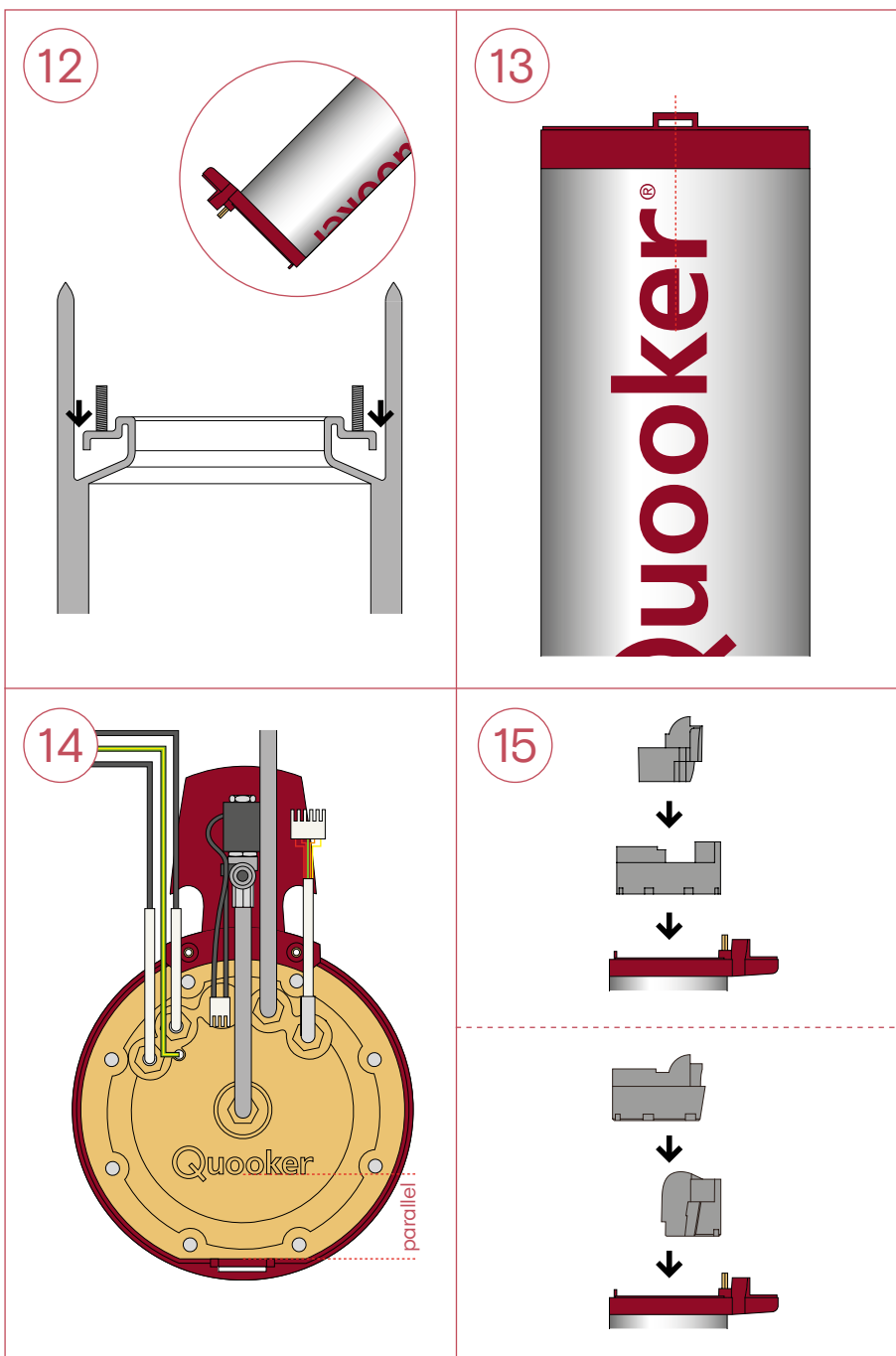

16. Place the two long hoses between the extended part of the red rim and the brass (distance) nut and push it downward.
17. Place the hose with the solenoid valve (black cube) over the middle of the insulation.
 - Plug the cable connectors into the cover.
18. Push the hose connector partly through the hole in the cover. Place the cover back in the notch. Push it further into place without pinching the cables. Secure the cap screws.
 - Connect the hose to the inlet combination using the large red fibre washer. Connect the tap hose to the tank with the small washer. Connect the LED cable. Plug the tank back in. Switch the socket on but not the tank yet.
19. Open the boiling-water tap, then the grey stop valve on the inlet combination and flush the tank through for a couple of minutes. Check for leaks. Switch on the tank.

Please note

After switching on the tank, the light should be on both the tap and tank. The tank will be fully heated and ready for use in around 10-20 minutes. After it has heated up, the tap light will go off and the tank light will change to a fading in and out (heartbeat light).

From time to time, unscrew the tap nozzle and descale the aerator in a vinegar-water solution.

For any further questions, do not hesitate to contact our service department on 0207 923 3355 (option 3 for service) or email us at: service@quooker.co.uk.

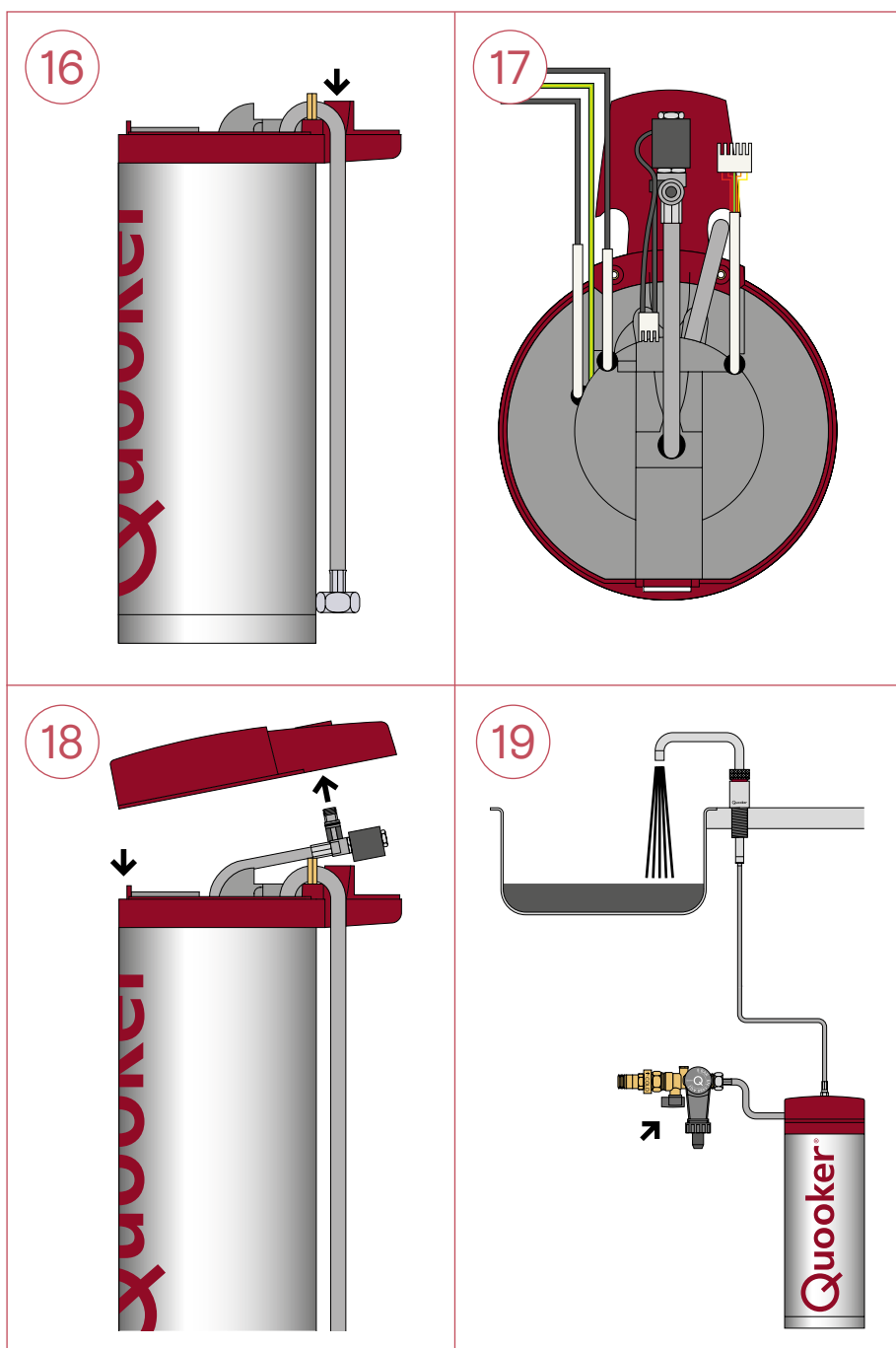

Quooker®

Quooker UK Ltd.
Beaumont Buildings
Great Ducie Street
Manchester
M3 1PQ (UK)
+44 (0)20 79233355
info@quooker.co.uk
www.quooker.co.uk